

300PSI

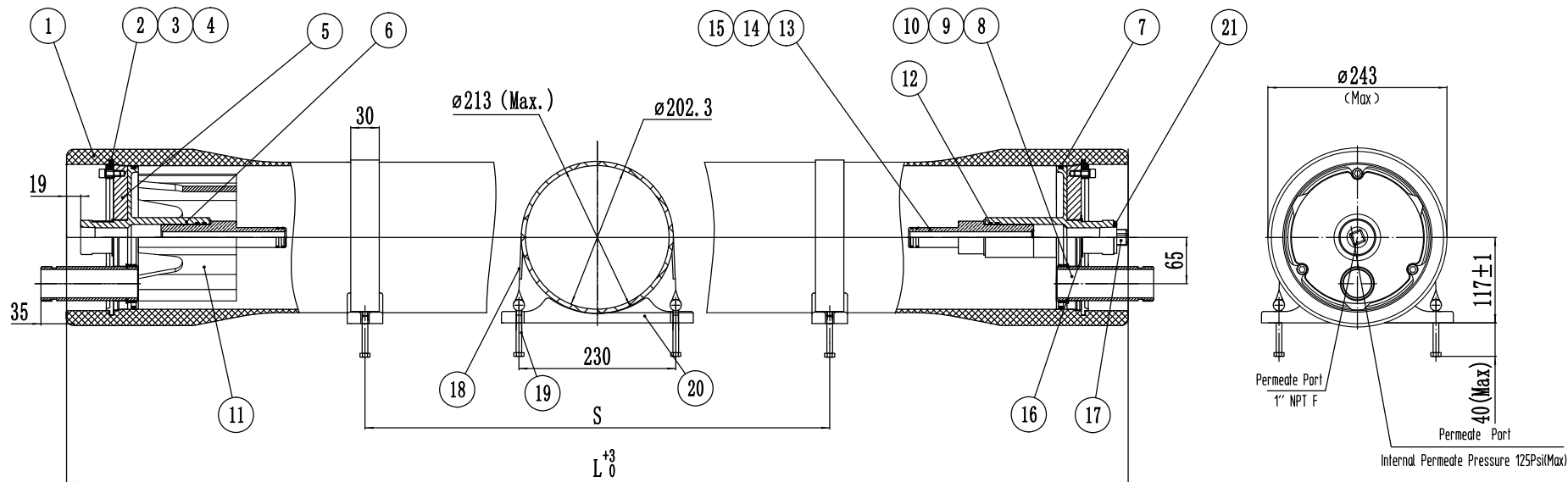

Note:

1. Design pressure: 300PSI (21Bar)
2. Design temperature: 150° F (66° C)
3. Minimum temperature: 14° F (-10° C)
4. Working medium: Water, PH 3-11
5. Please operate in accordance with User Guide
6. Flexible piping should be used on permeate connection to manifold
7. Subject to change without prior notice

Ref.	Part Number	L (MM)	S (MM)	Approx assembly weight (KG)
1	F8030E-1	1494	580	24
2	F8030E-2	2510	1350	30
3	F8030E-3	3526	2080	36
4	F8030E-4	4542	1600x2	42
5	F8030E-5	5558	2000x2	48
6	F8030E-6	6574	2360x2	54
7	F8030E-7	7590	2860x2	61
8	F8030E-8	8606	3370x2	67

21	O-ring	20000314	1	EPDM	36.5x3.55
20	Saddle	20000001	2-3	Rubber	
19	Strap Screw	20000198	4-6	304SST	M8*90
18	Strap	20000186	2-3	304SST-Rubber	
17	Plug	20000073	1	ABS	
16	Retaining Ring	20000383	2	304SST	
15	O-ring	20000316	4	EPDM	23.6x2.65
14	Adapter	20000364	2	ABS	
13	Adapter Pad	20000020	2	ABS	
12	O-ring	20000314	4	EPDM	36.5x3.55
11	Thrust Ring	20000420	1	ABS	
10	O-ring	20000318	4	EPDM	47.5*3.55
9	Retaining-ring	20000007	2	304SST	
8	Feed/Conc.Part	20000423	2	316LSST	
7	O-ring	20000901	2	EPDM	187x7
6	Seating Plate	200002336	2	ABS	
5	Bearing Plate	20000401	2	Aluminium Alloy	
4	Locking Kit Segment	20000006	6	304SST	
3	Spring Pad	20000197	6	304SST	ø8
2	LockingSegment Screw	20000196	6	304SST	M8x20
1	Pressure Shell	See SectionTable	1	Epoxy FRP	White
Ref.	Description	Part Number	Qty.	Material	Remark

**Harbin FirstLine Environment Technology Co., Ltd.**

<b>First Line</b>	Design	Model
	Date	F80-300E Pressure Vessel
	Review	
	Date	F80-30-E-00-01
	Review	
	Date	
Approval	Unit	REV.
Date	mm	2023