

1200PSI

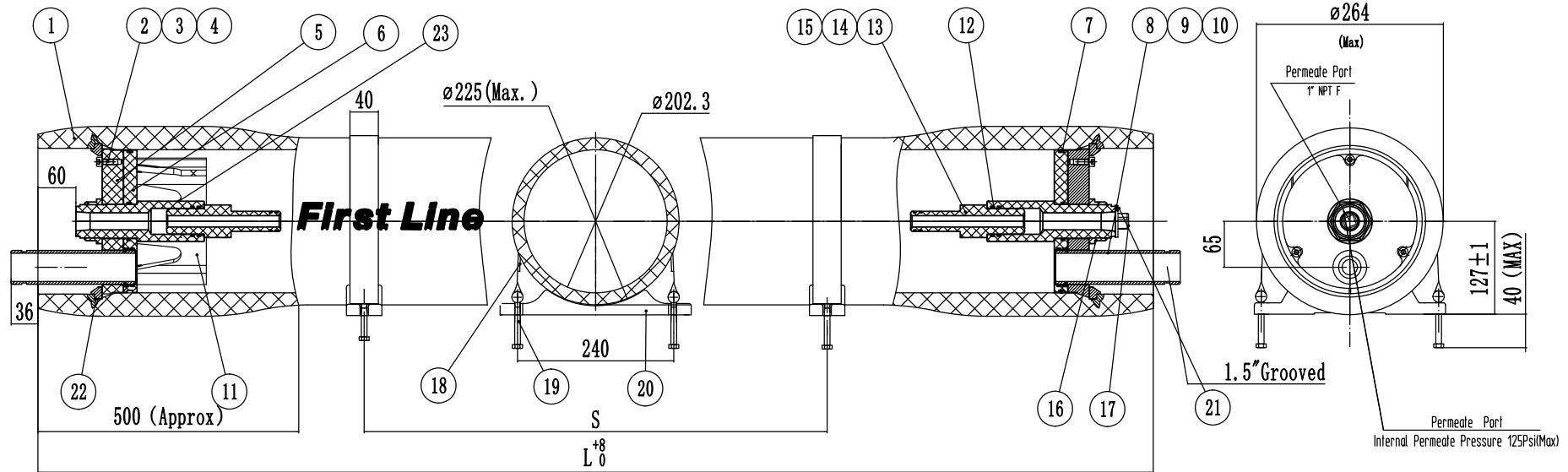

Note:

1. Design pressure: 1200PSI (83Bar)
2. Design temperature: 150° F (66° C)
3. Minimum temperature: 14° F (-10° C)
4. Working medium: Water, PH 3-11
5. Please operate in accordance with User Guide
6. Flexible piping should be used on permeate connection to manifold
7. Subject to change without prior notice

24	O-Ring	20000318	2	EPDM	47.5x3.55
23	Permeate Part	20002270	2	ABS	
22	Embedded Ring	30200026	2	316LSST	
21	O-Ring	20000314	1	EPDM	36.5x3.55
20	Saddle	20000002	2-3	Rubber	
19	Strap Screw	20000198	4-6	304SST	M8*90
18	Strap	20000188	2-3	304SST-Rubber	
17	Plug	20000073	1	ABS	
16	nul	20000698	2	ABS	
15	O-Ring	20000316	4	EPDM	23.6x2.65
14	Adapter	20002250	2	ABS	
13	Adapter Pad	20000020	2-10	ABS	
12	O-Ring	20000314	4	EPDM	36.5x3.55
11	Thrust Ring	20000420	1	ABS	
10	O-ring	20000318	4	EPDM	47.5x3.55
9	Retaining ring	20000383	2	304SST	
8	Feed/Conc.Part	20000425	2	2507SST	
7	O-Ring	20001074	2	EPDM	187x7
6	Split Sealing Plate	20001183	2	ABS	
5	Bearing Plate	20000403	2	Aluminium Alloy	
4	Locking Kit Segment	20000008 09 10	6	316LSST	
3	Spring Pad	20000197	6	304SST	φ8
2	Locking Segment Screw	20000196	6	304SST	M8x20
1	Pressure Shell	See Selection Table	1	Epoxy FRP	White
Ref.	Description	Part Number	Qty.	Material	Remark

Ref.	Part Number	L (MM)	S (MM)	Approx assembly weight (KG)
1	F80120E-1	1582	580	65
2	F80120E-2	2598	1350	81
3	F80120E-3	3614	2080	97
4	F80120E-4	4630	1600x2	113
5	F80120E-5	5646	2000x2	129
6	F80120E-6	6662	2360x2	140
7	F80120E-7	7678	2860x2	162
8	F80120E-8	8694	3370x2	184

Harbin FirstLine Environment Technology Co.,Ltd.

First Line	Design	Model
	Date	F80-1200E Pressure Vessel
	Review	
	Date	DRG
	Review	
Date		
Review	F80-120-E-00-01	
Date		
Approval	Unit	REV.
Date	mm	2023