



**MAX FLOW**  
FLUID SYSTEMS

Model F40 Series | 4" Standard Pressure Vessel

**F40-300S**  
**300 PSI**

## HISTORY

First Line is a new type of pressure vessel company with over 50 years of combined experience in FRP pressure vessel engineering and design, we specialize in the manufacture of high quality pressure vessels.

We design pressure vessels to provide long-term, trouble-free operation, with minimal down time and improve running costs.

First Line pressure vessels are manufactured for small to medium size to large commercial size plants. We offer pressure vessels in a variety of sizes that fit standard sized membranes offered by top membrane manufacturers. In addition we custom design vessels for high chemical resistance.

## APPLICATION

First Line pressure vessels are engineered for permeate and feed/concentrate with variable port options, connection types and sizes. Our pressure vessels are fully customizable and may be offered as OEM equipment.



## FEATURES

- Easy installation and trouble-free maintenance
- Custom designed and configured to customer specifications
- End port configuration
- 300 Psi, 450 Psi, 600 Psi, 1000 Psi, 1200 Psi

At First Line we engineer high quality pressure vessel solutions that fit your need. First Line uses only high quality materials and reliable parts that undergo rigorous quality control standards. Our highly experienced, trusted and trained engineers has performed numerous service installations worldwide.

Benefit from our experience.

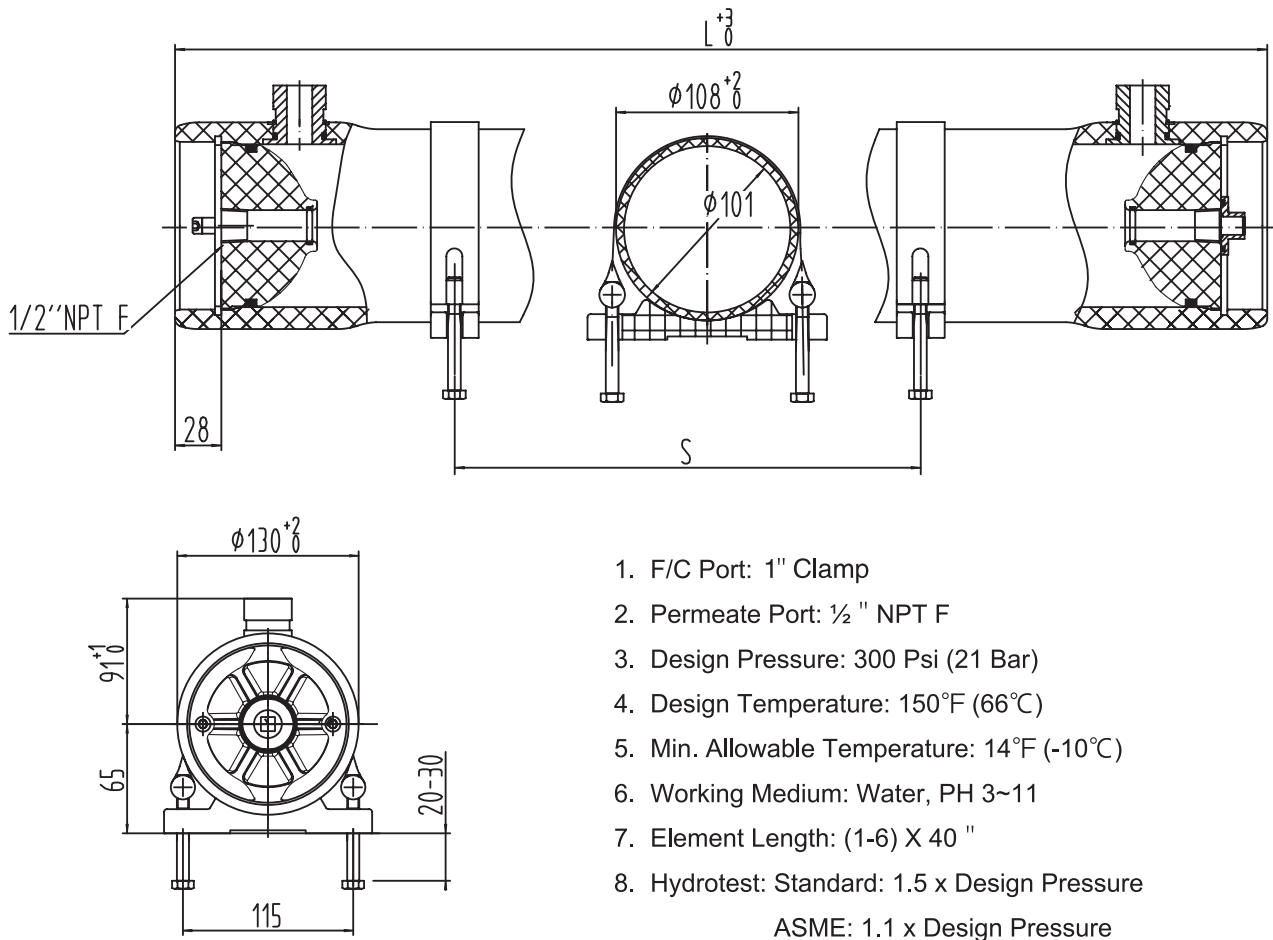

1. F/C Port: 1" Clamp
2. Permeate Port: 1/2" NPT F
3. Design Pressure: 300 Psi (21 Bar)
4. Design Temperature: 150°F (66°C)
5. Min. Allowable Temperature: 14°F (-10°C)
6. Working Medium: Water, PH 3~11
7. Element Length: (1-6) X 40"
8. Hydrotest: Standard: 1.5 x Design Pressure  
ASME: 1.1 x Design Pressure

Shell Length Code	Part Number	L (mm)	P (mm)	S (mm)
1	F40-300S-1	1,140	984	600
2	F40-300S-2	2,156	2,000	1,200
3	F40-300S-3	3,172	3,096	2,200
4	F40-300S-4	4,268	4,112	1,600 x 2
5	F40-300S-5	5,284	5,128	2,300 x 2
6	F40-300S-6	6,300	6,144	2,700 x 2



Harbin Firstline Environment Technology Co., Ltd. [First Line] reserves the right to modify the design and specification contained herein without prior notice. Please contact your local First Line sales representative for the most current information.